

INSTALLATION

EN

# UE MONOBLOC ATLANTIC

Monobloc Air to Water Heat Pump

Outdoor Unit

M 5 - 750731



M 6 - 750732

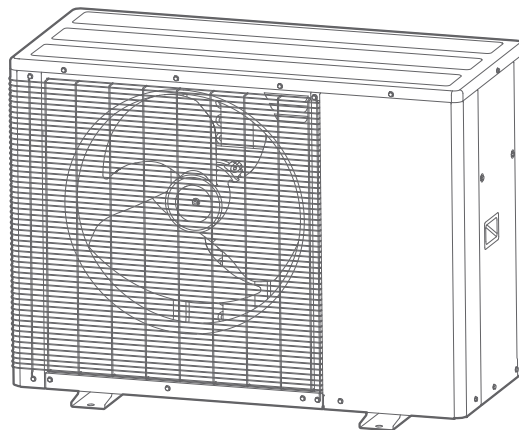

U0768357\_2460\_EN\_1  
03/10/2023

To be safety stored by the user for reference by installers.



### ■ Installation and maintenance rules

The appliance must be installed and maintained by an approved professional in accordance with current regulations and codes of practice.

- **Do not use any means to accelerate the defrosting process or to clean the appliance, other than those recommended by the manufacturer.**
- **The appliance must be stored in a room that does not contain ignition sources (for example: open flames, gas appliance or operating electric heater).**
- **Do not pierce or burn the appliance.**
- **Caution should be taken as refrigerant can cause a hazardous environment and be flammable, colourless, and/or odourless.**

### ■ Handling

The outdoor unit must be transported and stored in an upright position, avoiding tilting where possible.

If not kept upright during transport, the appliance could be damaged through displacement of the refrigerant and damage to the compressor mountings.

Any damage caused by not transporting in an upright position is not covered by the warranty.

If necessary, the outdoor unit may be tilted only during manual handling (to go through a door or a flight of stairs). This operation must be conducted very carefully and the appliance must be immediately restored to the upright position.

### ■ Installation

The heat pump installation must conform with the legislation and regulations of the installation site of the heat pump.

The heat pump is designed to be installed at an altitude less than 2.000m from sea level.

### ■ Hydronic connections

The connection must comply with industry standard practice according to current regulations.

Hydronic connections are to be made in accordance with industry standard practice for plumbing work using the following sealing methods where appropriate:

- Use suitable seals (fibre gasket, O-ring).
- Use Teflon or hemp tape.
- Use sealing paste (synthetic depending on the case).

Use glycol/water mix if the outdoor hydronic circuit is subject to a frost risk.

**For the outdoor hydronic circuit, use an insulation which is suitable for outdoor use and is UV/moisture-resistant (usage temperature -20 to +70 °C). The thermal conductivity of the insulation is less than or equal to 0.040 W / mK.**

**it is mandatory that either antifreeze valves or a glycol/water mix are installed to protect the hydronic circuit and associated components.**

If you are using a glycol/water mix, arrange for an annual check on the quality of the glycol.

Use monopropylene glycol only. The recommended concentration is 40% max. (30% minimum).

**Never use monoethylene glycol.**

**Both antifreeze valves and a glycol/water mix must not be applied together in the same circuit.**

- **In some installations, the presence of different metals can cause corrosion problems; the formation of metal particles and sludge can appear in the hydronic circuit.**
- **In this case, it is advisable to use a corrosion inhibitor in the proportions indicated by the manufacturer.**
- **You must also ensure that treated water does not become corrosive.**

**Mandatory : Install a Sediment trap (not supplied) on the heating return circuit in the manner suggested.**

**Caution: Do not close water valves (between Outdoor unit & Indoor unit) during operating the heat pump.**



## ■ Electrical connections

**Before performing any maintenance, make sure that all power supplies have been isolated.**

### • Specifications of electricity supply

The electrical installation must be carried out in accordance with current regulations. Wiring external to the heat pump must be in accordance with the current I.E.E. (BS7671) wiring regulations and any local regulations.

Electrical connections must only be made once all other installation operations (fastening, assembly, etc.) have been completed.

#### **Warning!**

The power supply from the energy provider must be sufficient not only to cover the heat pump's power requirements but also the combined sum of all the appliances likely to be operating at the same time. If the power is too low, check the power rating stated in your contract with your energy provider.

Never use a power socket for the power supply to the heat pump.

The heat pump must be supplied directly with power by protected leads from the electric panel via dedicated bipolar circuit breakers, C curve for the outdoor unit, C curve for the electrical heating\* and domestic water backups\*.

The electrical installation must be fitted with a 30mA RCD.

This appliance is designed to operate using a nominal voltage of 230V +/- 10%, 50 Hz.

### • General remarks on electrical connections

It is essential to maintain neutral-phase polarity when making electrical connections.

Rigid wires are preferable for fixed installations, particularly in a building.

Tighten the cables using cable ties to prevent the power cables from being accidentally disconnected.

The earth connection and its continuity must be ensured.

The earth wire must be longer than the other wires.

- Connecting to screw terminals

**The use of ring, spade or blade terminals or caps is prohibited.**

- Always select wire that complies with current standards.
- Strip wire end around 25 mm.
- With round end pliers, form a loop with a diameter which matches the tightening screws on the terminal.
- Tighten the terminal screw firmly onto the loop created. Insufficient tightening can cause overheating, leading to breakdown or even fire.

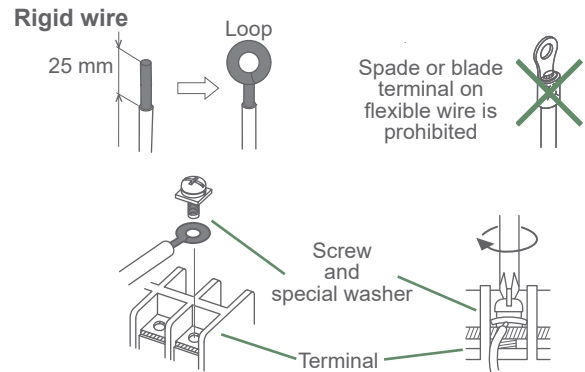









(\* dependant on installation)

---

# Contents

---

 <b>Presentation of the equipment</b>	<b>6</b>
Packing list . . . . .	6
Specification . . . . .	8
Operating principle . . . . .	10
 <b>Location</b>	<b>12</b>
Installing the outdoor unit . . . . .	12
 <b>Hydronic connection</b>	<b>16</b>
Rinsing the installation . . . . .	16
Hydronic connection of the outdoor unit . . . . .	16
 <b>Electrical connection</b>	<b>18</b>
Cable routing . . . . .	18
Cable size and protection rating . . . . .	19
 <b>Appendices</b>	<b>20</b>
Electrical cabling diagram . . . . .	20
 <b>Commissioning</b>	<b>21</b>
 <b>Instructions for the user</b>	<b>21</b>
 <b>Heat pump error code</b>	<b>22</b>

 Make sure that these instructions, safety instructions, local regulations, local legislation, and guidelines are read and understood before installation and/or maintenance.

#### Unpacking and delivery

 While the courier is still present, carefully check the general appearance of the appliances.

 Check the package codes that make up your device.

In the event of a problem with the packaged product, send any relevant problems to the carrier in writing within 48 hours and send a copy of the letter to Customer Services.

 This document was written in French and translated.

## ► Symbols and definitions



Warning. Risk of serious injury to the person and / or risk of damage to the machine. Observe the warning.



Important information that must always be kept in mind.



Tips and tricks / Advice.



Bad practice.



Warning : Electricity hazard.



Warning : Slightly flammable refrigerant.



Read the installation manual.



Read the Operating Manual.



Read the instructions.

# Q Presentation of the equipment

## ► Packing list

### ■ 1 package : Outdoor unit

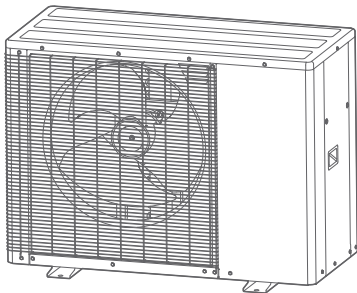

Model		Code
Outdoor unit	UE MONOBLOC ATLANTIC 5	750731
	UE MONOBLOC ATLANTIC 6	750732

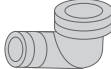
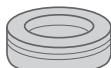
Accessories	
	Elbow
	Plug (x9)

The outdoor unit can be associated with an indoor unit 1 service , DHW ou a Compact unit

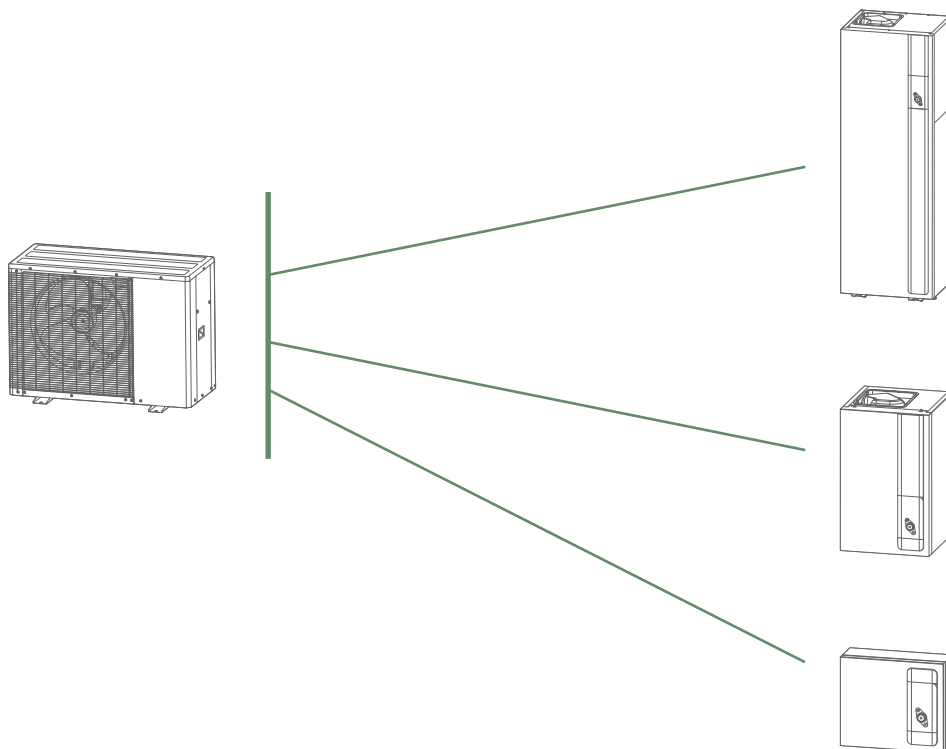

## ▼ Optional accessories

- Antifreeze valve kit (Ref. 074863)  
to protect the hydraulic outdoor circuit.
- Glycol 20 L (Ref. 700429)
- Sediment trap (Ref. 074090)
- Rubber feet kit (Ref. 074241)
- Trace heating cable (Ref. 809644)
- Condensate drain tray (Ref. 074862)

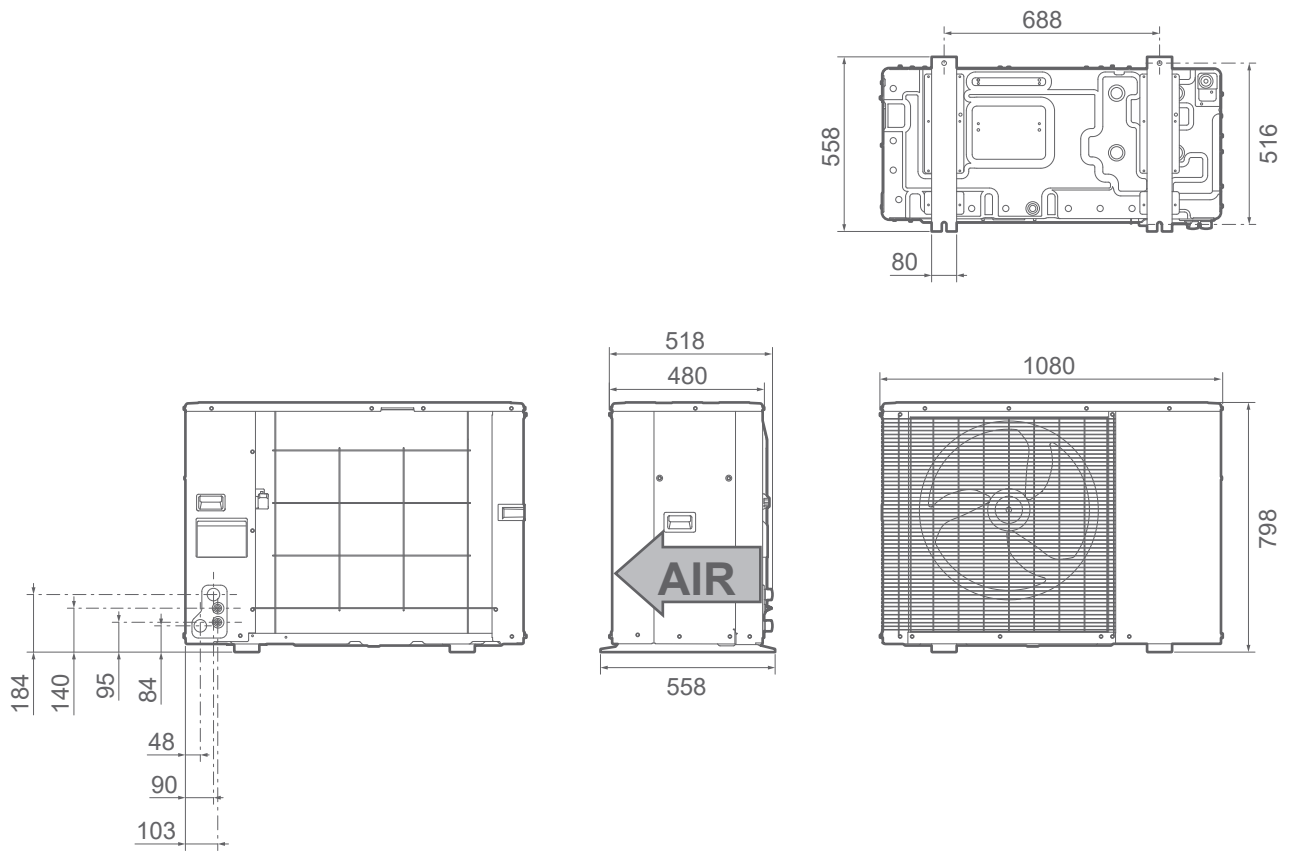

fig. 1 - Dimensions (in mm)

OUTDOOR UNIT		Code 75***				090761...A	
	1	2	3	4			
Compressor / Compresseur	1 - R901z - 230V	***3M	***4M	***A	R32	GWP 675	1 Supply voltage Tension d'alimentation 2 Heat output (17°C/35°C) Puissance absorbée 3 Power absorbed Puissance absorbée 4 Maximum current intensité max weight / poids
REFRIGERANT / FROUILLANT (R32) FLUIDE REFRIGERANT (R32) REFRIGERANT (R32) - REFRIGERANT (R32) - REFRIGERANT (R32)							5 6 7 8 9 10 11 12 13 14 15 16 17 18 19 20 21 22 23 24 25 26 27 28 29 30 31 32 33 34 35 36 37 38 39 40 41 42 43 44 45 46 47 48 49 50 51 52 53 54 55 56 57 58 59 60 61 62 63 64 65 66 67 68 69 70 71 72 73 74 75 76 77 78 79 80 81 82 83 84 85 86 87 88 89 90 91 92 93 94 95 96 97 98 99 100
MAXIMUM PRESSURE REFRIGERATION CIRCUIT PRESSION MAX. CIRCUIT FROUILLANT (R32)					4.2 MPa (61.2 bar)		
HEAT TRANSFER FLUID FLUIDE CALORIFICATEUR					Water Eau		
MAX. OPERATING PRESSURE COOLANT FLUID PRESSION MAX. CIRCUIT CALORIFICATEUR					0.3 MPa (3 bar)		
INGRESS PROTECTION INDICE DE PROTECTION					IPX4		
OUTDOOR TEMPERATURE LIMITS FOR HEATING / DRW OPERATION LIMITES DE FONCTIONNEMENT CHAUFFAGE / ECR					-20/+6°C	Serial Number 075*****	
Manufacturing site (GROUPE ATLANTIC) Rue des Fondaires BP64 9840 MERVILLE France						Date 09/2022	

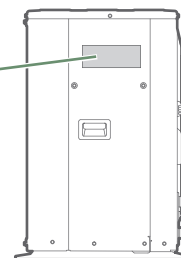

fig. 2 - Location of Data Plate

## ► Specification

<b>Model name</b>		<b>5</b>	<b>6</b>
<b>Nominal heating performances (outdoor temperature/ initial temperature)</b>			
<b>Heat output</b>			
+7°C / +35°C	kW	4.0	5.0
-7°C / +35°C	kW	4.1	5.1
+7°C / +55°C	kW	4.0	5.0
-7°C / +55°C	kW	3.7	4.8
<b>Power consumption</b>			
+7°C / +35°C	kW	0.75	0.97
-7°C / +35°C	kW	1.28	1.63
+7°C / +55°C	kW	1.33	1.64
-7°C / +55°C	kW	1.84	2.25
<b>Coefficient of performance (COP)</b>		<b>(+7°C/+ 35°C) 5.34</b>	<b>5.15</b>
<b>Electrical characteristics</b>			
<b>Power Supply Requirements</b>			
Electrical voltage (50 Hz) 1-phase	V	230	230
Maximum current	A	13.1	14.6
<b>Hydronic circuit</b>			
Connection size / pipe diameter	Inches	1" - 25.4mm	1" - 25.4mm
Maximum operating pressure	MPa (bar)	0.3 (3)	0.3 (3)
Minimum flow rate of the hydraulic circuit	l/min	8.5	8.5
<b>Miscellaneous</b>			
Weight (empty)	kg	85	85
Maximum Acoustic power level	dB (A)	60	62
ERP Acoustic pressure level (5m / EN 12102-1 Annex A) <sup>1</sup>	dB (A)	52	52
Acoustic power level (EN 14511-2 / A7W55) <sup>2</sup>	dB (A)	57	59
<b>Heating system operating limits</b>			
Min /max outdoor temperature	°C	-20 / +35	-20 / +35
Initial max. heating water temperature Under-floor heating	°C	45	45
Max. water temperature for radiator heating	°C	60	60
Initial min. water temperature (may require auxiliary heater)	°C	17	17
<b>Refrigerant circuit</b>			
Factory charge of refrigerating fluid R32 <sup>3</sup>	g	880	880
Maximum operating pressure	MPa (bar)	4.2 (42)	4.2 (42)

<sup>1</sup> Sound pressure level at (x) m from the appliance, 1.5m from the ground, free field, directivity 2.

<sup>2</sup> The acoustic power is a measurement made in the laboratory of the power of the noise emitted but contrary to the noise level, it does not correspond to the measurement of what is felt.

<sup>3</sup> Refrigerant R32 in compliance with standard BS EN 378-1.



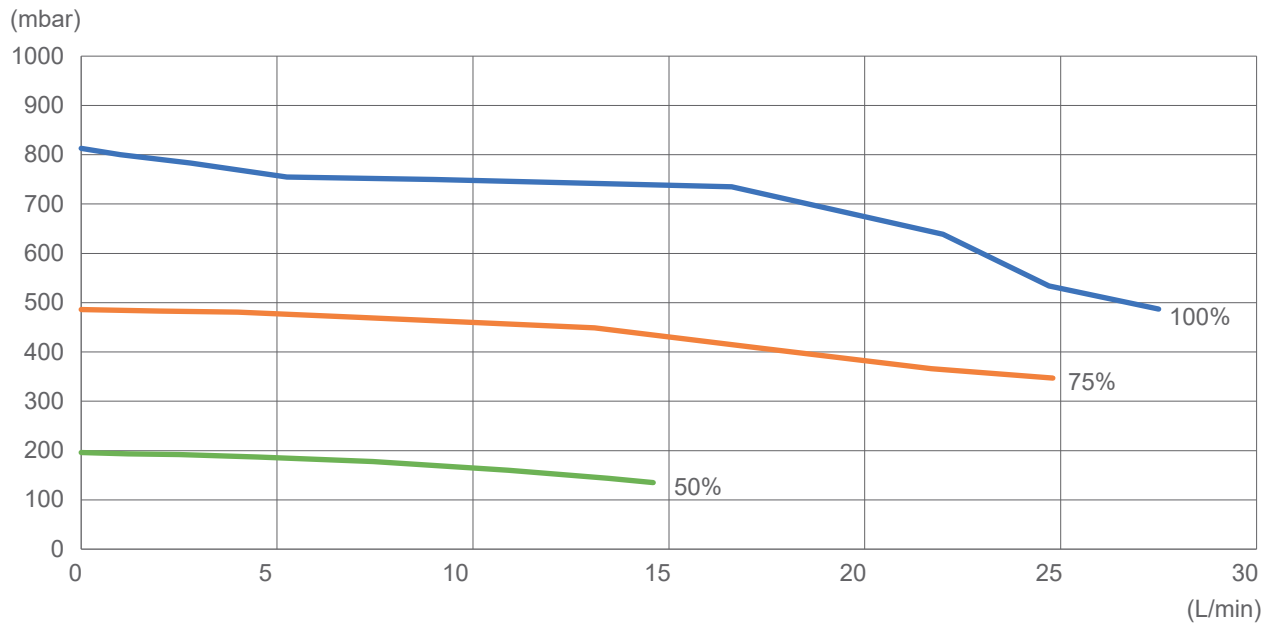
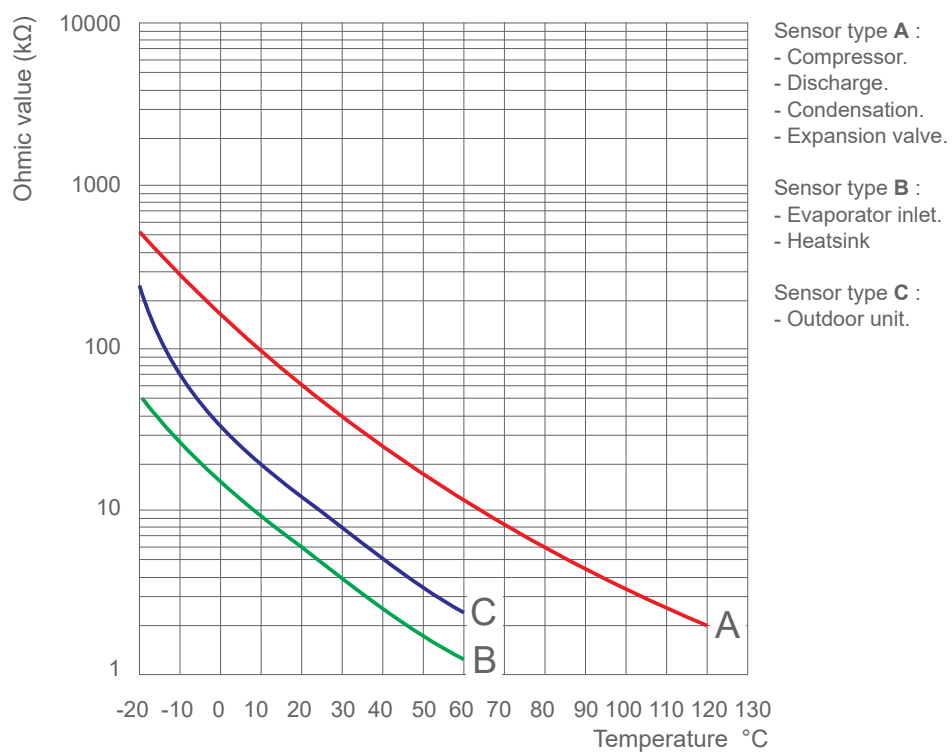

fig. 3 - Outdoor unit available hydronic pressures and flow rates



- Sensor type **A** :
  - Compressor.
  - Discharge.
  - Condensation.
  - Expansion valve.
- Sensor type **B** :
  - Evaporator inlet.
  - Heatsink
- Sensor type **C** :
  - Outdoor unit.

fig. 4 - Ohmic sensor values (Outdoor unit)

## ► Operating principle

The Monobloc Outdoor unit, as its name suggests, is placed outside your dwelling, and extracts energy from the outside air.

The Monobloc Outdoor unit is designed to be controlled by the Indoor unit to heat the circuit by transfer heat from this air to the water.

Nothing should obstruct the air passage through the evaporator and out from the fan.

The water contained in the air may condense and flow out of the outdoor unit. The outdoor unit can generate a large volume of water called condensate.

In cold weather, this water freezes on contact with the exchanger and must be regularly removed through defrosting cycles. The defrosting cycle is managed automatically by the control system and can produce steam emissions which are completely normal.

The Outdoor unit is equipped with a circulating pump to transfer the water flow to the water through pipings. The speed of the pump can be adjusted by the Indoor unit.

The heating circuit flow temperature is controlled by Indoor unit.

Depending on the heating flow temperature demand, the Outdoor unit's power is modulated by an inverter controller compressor.

A minimum water flow is required to have optimized exchange, this is controlled by a water flow sensor (flowmeter).

A communication line allows information to be transferred between the indoor and outdoor unit such as heating demand signal and fault status.

### ■ Protective functions

- Frost protection: Frost protection activates if the heating circuit's flow temperature falls below 4 °C (provided that the heat pump's electrical power supply is active).
- The flow rate sensor checks that the flow rate is higher than the required minimum value.
- The hydronic circuit is equipped with a 3 bar pressure relief safety valve.

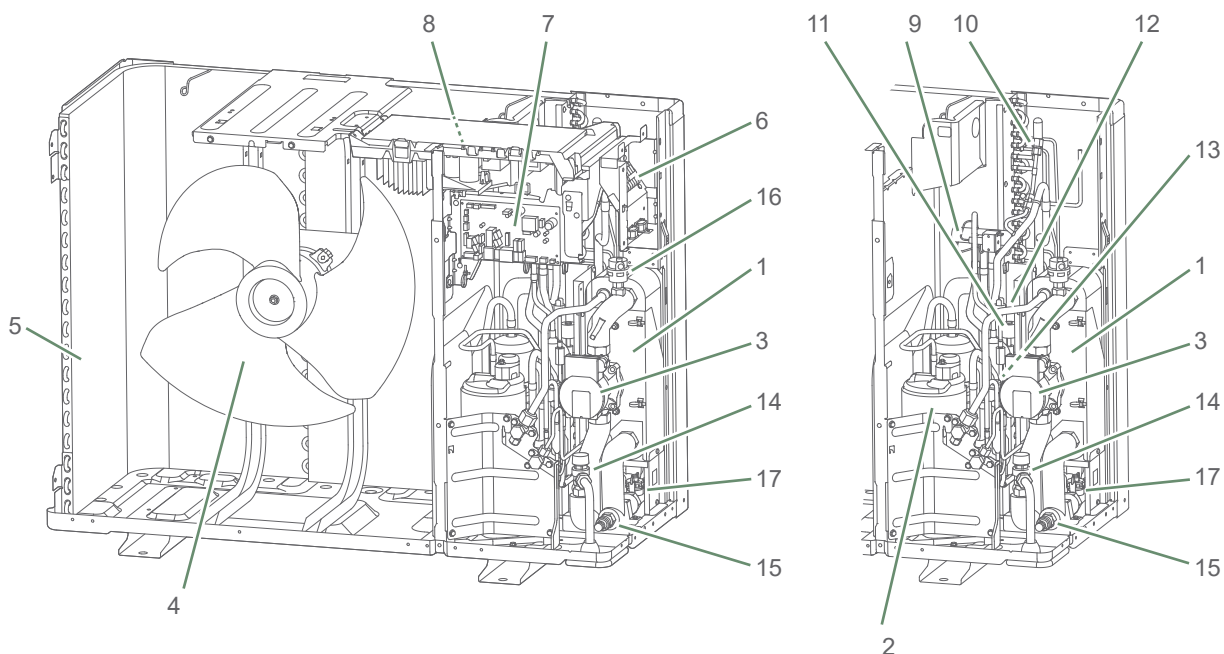

1. Refrigerant to Water Heat Exchanger (EP)
2. Compressor (Cp)
3. Circulating pump (CC)
4. High performance and low noise fan
5. Air to Refrigerant Heat Exchanger (Ech)
6. Supply terminal

7. Hydronic Circuit PCB
8. Main PCB
9. 4-way valve (V4V)
10. Schrader Valve
11. Pressure sensor (SPr)
12. High pressure switch (Prt)

13. Expansion valve (Dt)
14. Pressure Relief Valve (SSe)
15. Drain valve (V)
16. Automatic bleeder valve (PgA)
17. Flowmeter (Db)

fig. 5 - Components

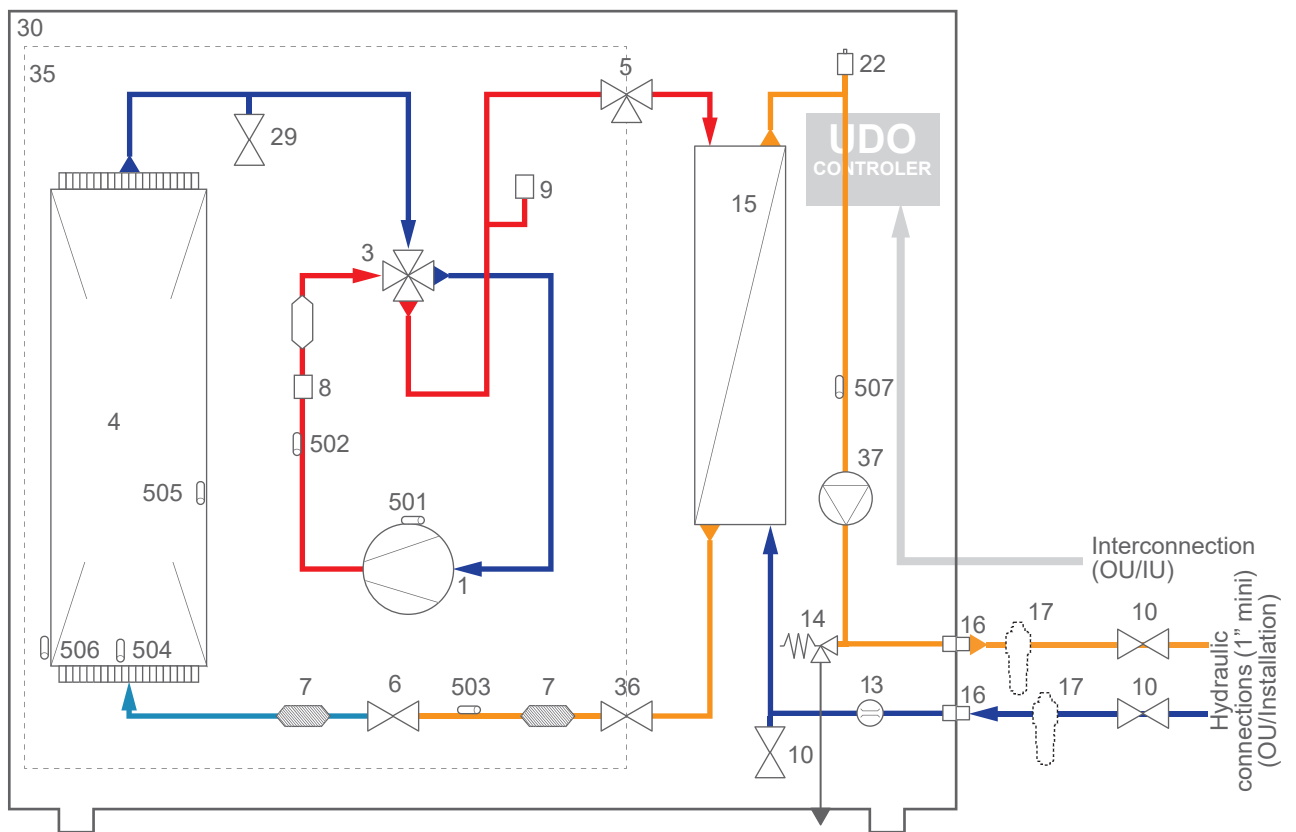

- 1 - Compressor
- 3 - 4-way valve
- 4 - Air to Refrigerant Heat Exchanger
- 5 - 3-way valve
- 6 - Expansion valve
- 7 - Filter
- 8 - Pressure switch (On/Off)
- 9 - Pressure sensor
- 10 - Valve
- 13 - Flow-meter

- 14 - Pressure Relief Valve
- 15 - Refrigerant to Water Heat Exchanger
- 16 - Hydraulic connection 1"
- 17 - Antifreeze valve
- 22 - Automatic bleeder valve
- 29 - Schrader valve
- 30 - Outdoor unit
- 35 - Refrigerant unit
- 37 - HP circulation pump IPWM
- 501 - Compressor temp. sensor

- 502 - Discharge temp. sensor
- 503 - Electric expansion valve sensor
- 504 - Outdoor temp. sensor
- 505 - Heat Ex. middle temp. sensor
- 506 - Outdoor unit Heat Ex. liquid temp. sensor
- 507 - Water outlet temp. sensor

# Location

## ► Installing the outdoor unit

### ▼ Installation precautions



**The outdoor unit must only be installed outdoors. If a shelter is required, it must have broad openings on all 4 walls and comply with the installation clearances.**

- Choose the installation site after talks with the customer.
- It is preferred that the outdoor unit is protected from wind and installed in a sunny area.
- Be sure to install the outdoor unit as prescribed, so that it can withstand earthquakes and typhoons or other strong winds. Improper installation can cause the unit to topple or fall, or other accidents.
- The unit must be easily accessible for future installation and maintenance work.
- Ensure that the connectors can be easily connected to the hydronic unit.

- The outdoor unit can be exposed to bad weather, however avoid installing it in places where it will become dirty or have excessive water dripping onto it (for example under a leaky drainpipe).
- Do not install the outdoor unit in the following areas:
  - Areas with high salt content in the air such as coastal areas. It will deteriorate metal parts, causing the parts to fail or the unit to leak water.
  - Area that generates substances that adversely affect the equipment, such as sulfuric gas, chlorine gas, acid, or alkali. It will cause the copper pipes and brazed joints to corrode, which can cause refrigerant leakage.
  - Area where animals may urinate on the unit or ammonia may be generated.
- When operating water may escape from the outdoor unit. Do not install the appliance on a terrace; install it in a well-drained location (bed of gravel or sand). If installed in a region where the temperature may drop below 0 °C for a long period of time, check that the ice does not cause any danger. A drainage pipe can also be connected to the outdoor unit (see *"Connecting the condensate evacuation pipe"*, page 13).

- A ≥ 100 mm
- B ≥ 150 mm
- C ≥ 200 mm
- D ≥ 300 mm
- E ≥ 400 mm
- F ≥ 500 mm
- G ≥ 600 mm

- H ≥ 1000 mm
- J ≥ 1500 mm
- K ≥ 3000 mm
- L ≥ 3500 mm
- M = 300 mm Max
- N = 500 mm Max

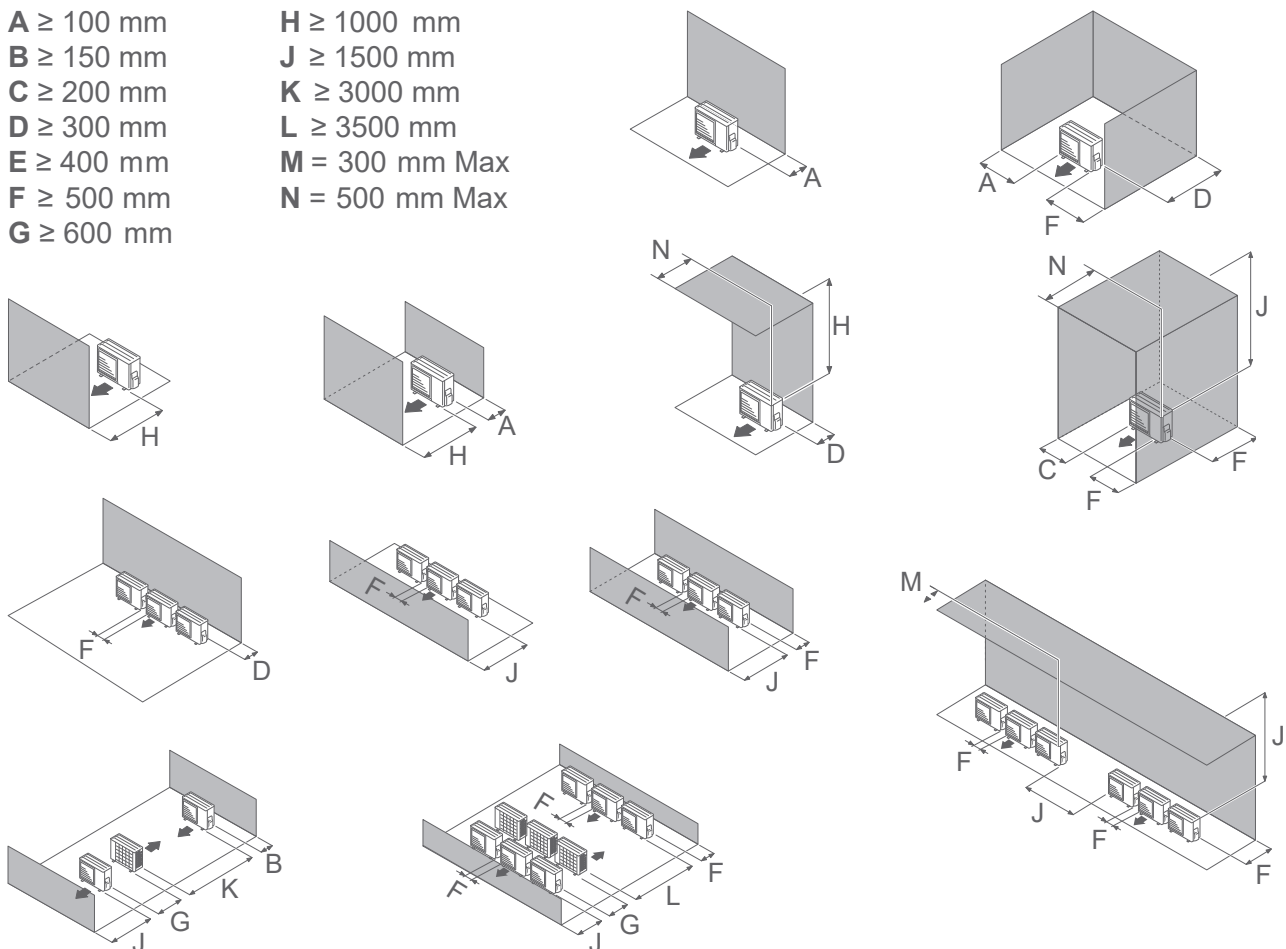

fig. 6 - Minimum installation clearances around the outdoor unit

- Nothing should obstruct the air from circulating through the evaporator and out of the fan.
- Keep the outdoor unit away from sources of heat or inflammable products.
- Ensure that the appliance does not disturb neighbours or users (noise level, draughts caused, low temperature of the air blown causing a risk of freezing plants in its path).
- The surface on which the outdoor unit is mounted must:
  - Be permeable (earth, gravel bed...),
  - Support the weight comfortably,
  - Permit it to be solidly attached,
  - Not transmit any vibration to housing. Anti-vibration pads are available as an optional extra.
- The outdoor unit must be firmly fastened to the ground.

#### ▼ Positioning the outdoor unit



**Do not tilt the outdoor unit more than 0.3 degrees.**

The outdoor unit must be raised by at least 50 mm from the ground. In snowy regions, this height must be increased but must not exceed 1.5 m.

Fasten the outdoor unit using screws and elastic tightening or toothed lock washers to prevent them from coming loose.



**In regions with heavy snowfall, if the outdoor unit's entrance and exit are blocked by snow it may be difficult to heat up and may cause breakdown.**

Build a canopy or position the unit on a high stand (local configuration).

- Put the appliance on a solid support to minimise impact and vibration.
- Do not set the unit directly on the ground as this may generate disruptions.

#### ▼ Connecting the condensate evacuation pipe



**The outdoor unit may generate a large volume of water.**

If the use of a drain hose is imperative:

- Install the condensate drain tray (optional). Use the elbow provided and connect a 16 mm-diameter hose / pipe for draining the condensate.
- Provide for the gravitational discharge of the condensates (waste water, rainwater, gravel bed).



**If the appliance is installed in a region where the temperature may fall below 0 °C for long periods, fit the drain hose and condensate drain tray with a heating cable to prevent it from icing over.**

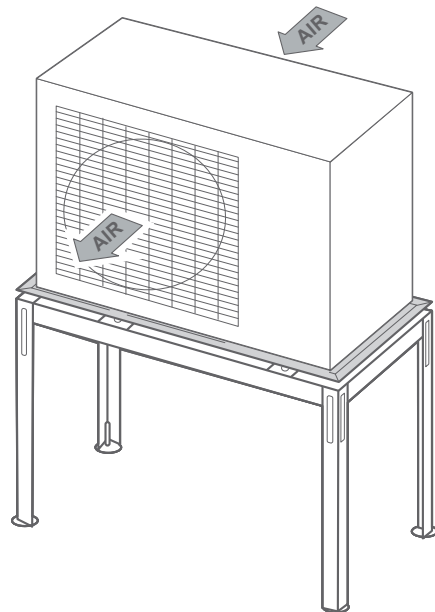

fig. 7 - High stand (optional)

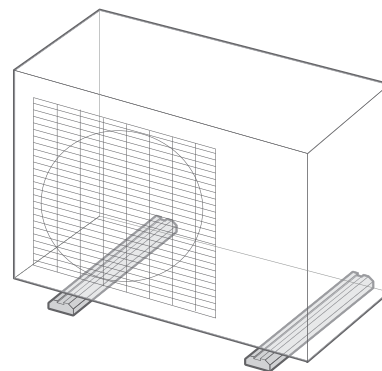
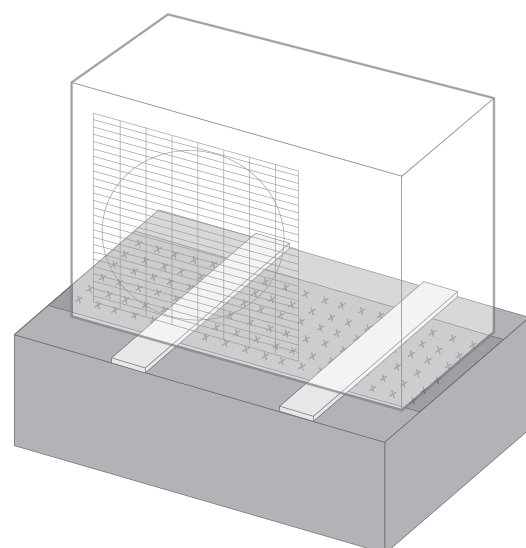
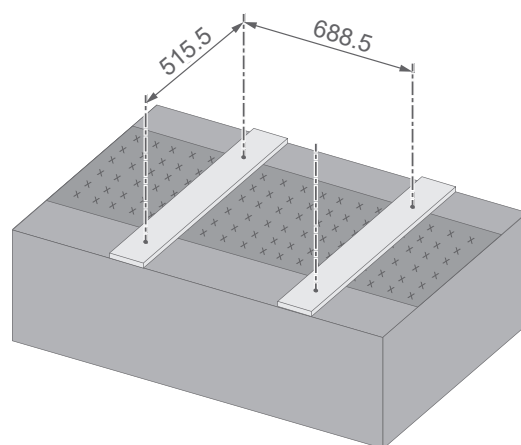
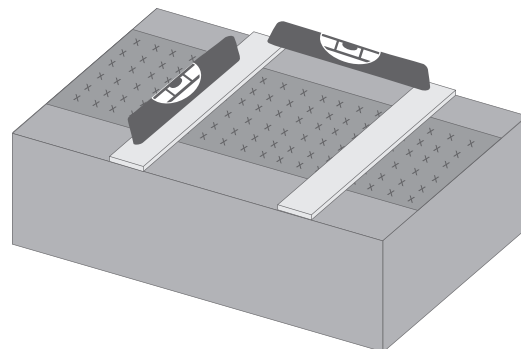
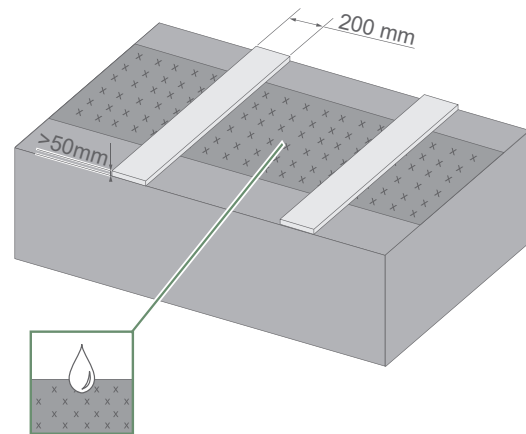

fig. 8 - Rubber feet arrangement (optional)



**OUTDOOR UNIT**

**85 kg**



OUTDOOR UNIT

85 kg

fig. 9 - Base of the outdoor unit

## OUTDOOR UNIT INSTALLATION



The outdoor unit may generate a large volume of water.

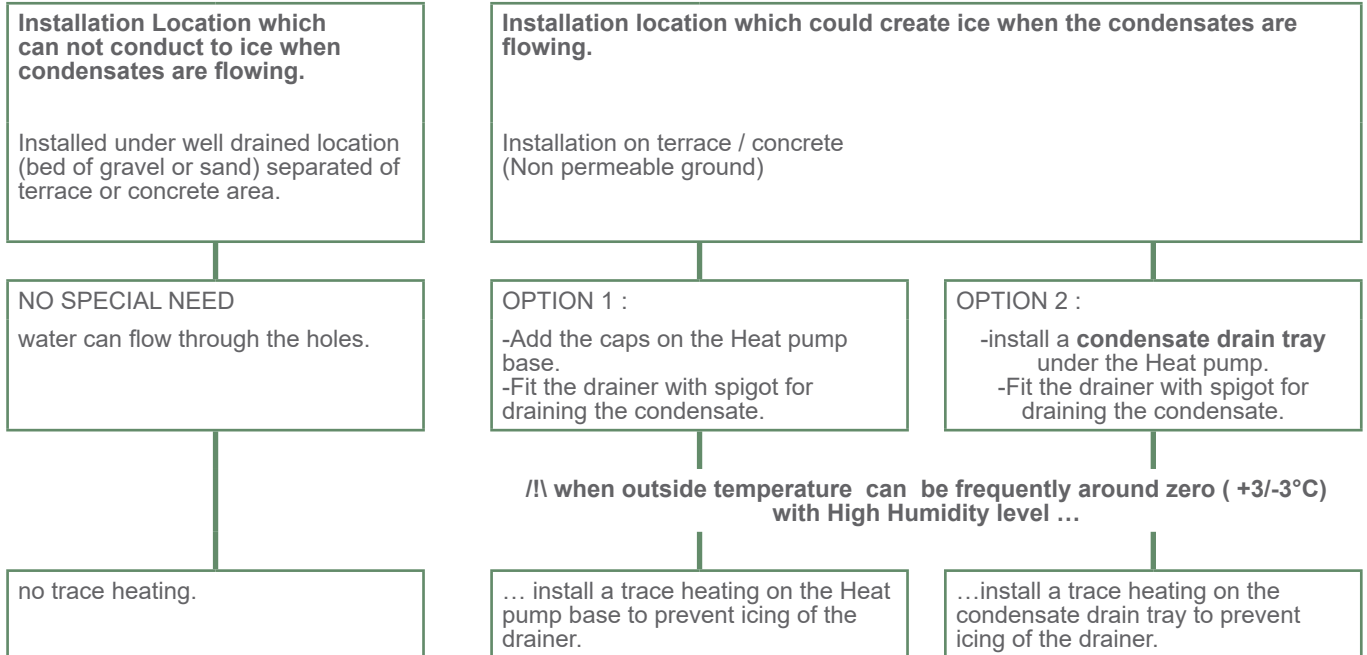

When operating water may escape from the Heat pump. Do not install the appliance on a terrace; install it in a well-drained location (bed of gravel or sand). If installed in a region where the temperature may drop around 0°C for a long period of time, check that the ice does not cause any danger.

# Hydronic connection

## ► Rinsing the installation



Before connecting the hydraulic unit to the installation, rinse the heating system correctly to eliminate the particles that could compromise the correct operation of the appliance.

Do not use solvents or aromatic hydrocarbons (petrol, paraffin, etc.).

In some installations, the presence of different metals can cause corrosion problems; the formation of metal particles and sludge can appear in the hydronic circuit. In this case, it is advisable to use a corrosion inhibitor in the proportions indicated by the manufacturer. You must also ensure that treated water does not become corrosive (neutral pH: 7 < pH < 9).



The system must be filled with heating water that complies with the standard.

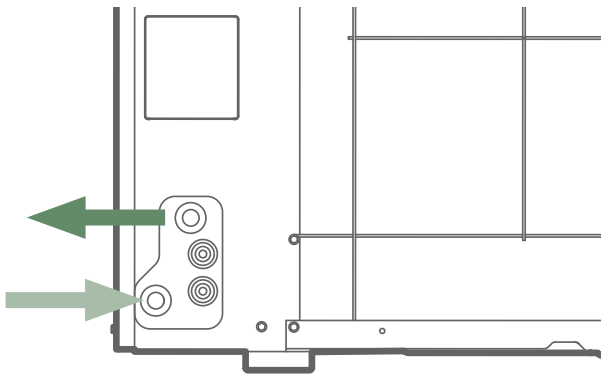

## ► Hydronic connection of the outdoor unit

Connect the pipe of the outdoor unit to the hydronic unit respecting the direction of flow.



it is mandatory that either antifreeze valves or a glycol/water mix are installed to protect the hydronic circuit and associated components.



**Mandatory :** Install a Sediment trap (not supplied) on the heating return circuit in the manner suggested.

Use union connectors to facilitate removal.

Connect the pipe of the central heating to the hydronic unit respecting the direction of flow.

The pipe between the hydraulic unit and the heat collector must be **at least 1" diameter** (26x34 mm).

Use union connectors to facilitate removal.

Prioritise connector hoses to avoid transmitting noise and vibrations to the building.

Tightening torque:

Ø	Tightening torque
1/2"	25 Nm
3/4"	35 Nm
1"	45 Nm
1-1/4"	60 Nm



maximum OU/IU pipes length : 30m.



**Warning :** Minimum volume of water in the free circulating loop: 24 liters

Connect the pipe (Ø15mm) of the pressure relief valve to the main sewer system.

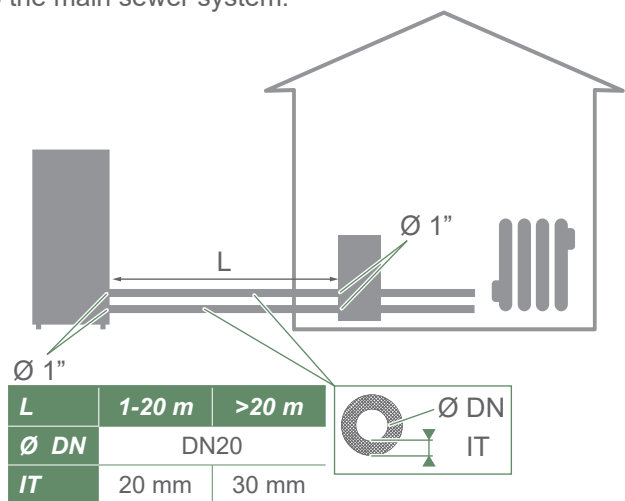

**Caution:** Do not close water valves (between Outdoor unit & Indoor unit) during operating the heat pump.

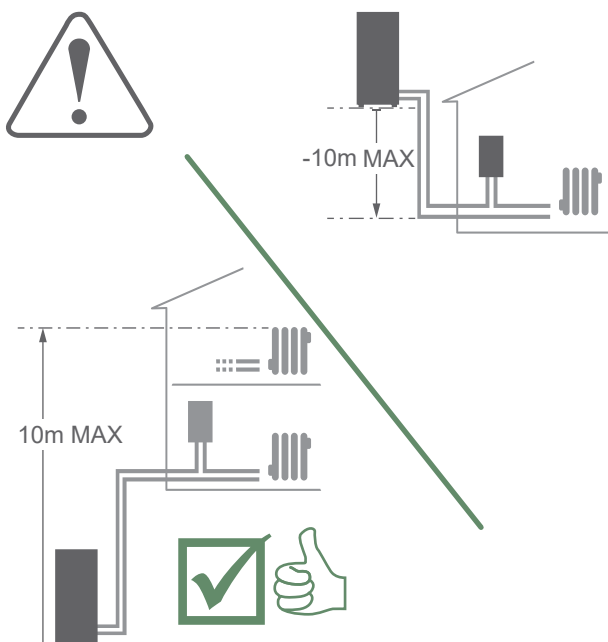



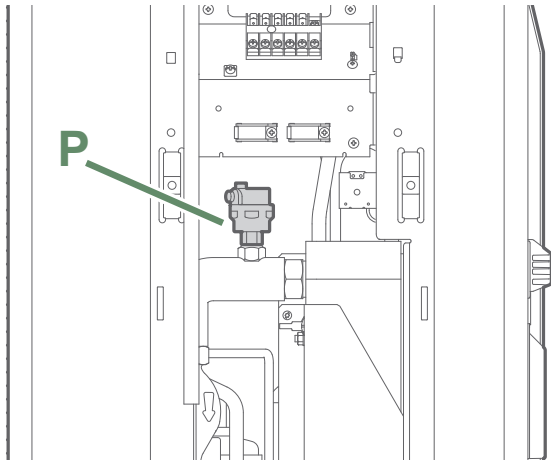

Open the bleed valve during the installation's filling.

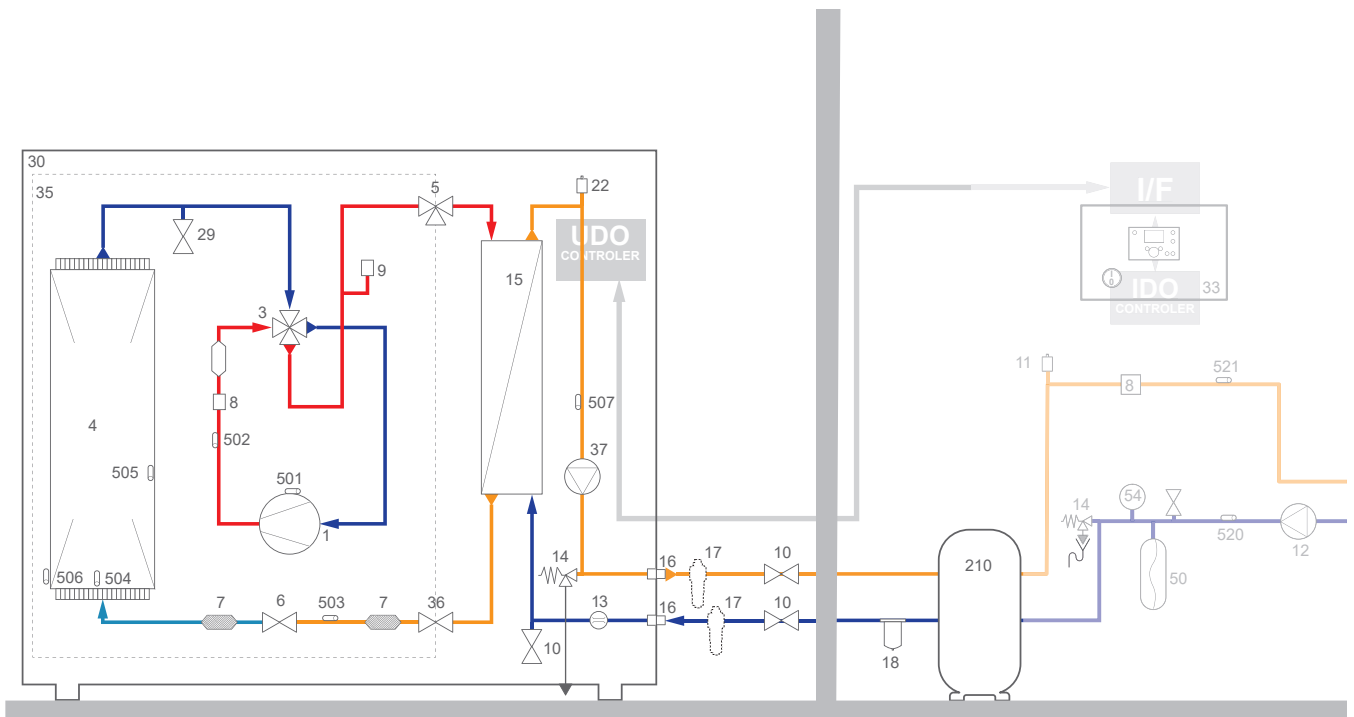

- 1 - Compressor
- 3 - 4-way valve
- 4 - Air to Refrigerant Heat Exchanger
- 5 - 3-ways valve
- 6 - Expansion valve
- 7 - Filter
- 8 - Pressure switch (On/Off)
- 8 - High pressure switch
- 9 - Pressure sensor
- 10 - Valve
- 11 - Bleeder valve
- 12 - Circulation pump

- 13 - Flow-meter
- 14 - Pressure Relief Valve
- 15 - Refrigerant to Water Heat Exchanger
- 16 - Hydraulic connection 1"
- 17 - Antifreeze valve
- 22 - Automatic bleeder valve
- 30 - Outdoor unit
- 35 - Refrigerant unit
- 37 - HP circulation pump IPWM
- 50 - Expansion vessel
- 54 - Manometer

- 210 - Buffer tank
- 320 - Return temp. sensor
- 501 - Compressor temp. sensor
- 502 - Discharge temp. sensor
- 503 - Electric expansion valve sensor
- 504 - Outdoor temp. sensor
- 505 - Heat Ex. middle temp. sensor
- 506 - Outdoor unit Heat Ex. liquid temp. sensor
- 507 - Water outlet temp. sensor
- 521 - Flow temp. sensor

fig. 10 - Basic Hydronic Layout

# Electrical connection



Before performing any maintenance, make sure that all power supplies have been isolated. Electrical installation must be performed in accordance with current regulations.



## ► Cable routing

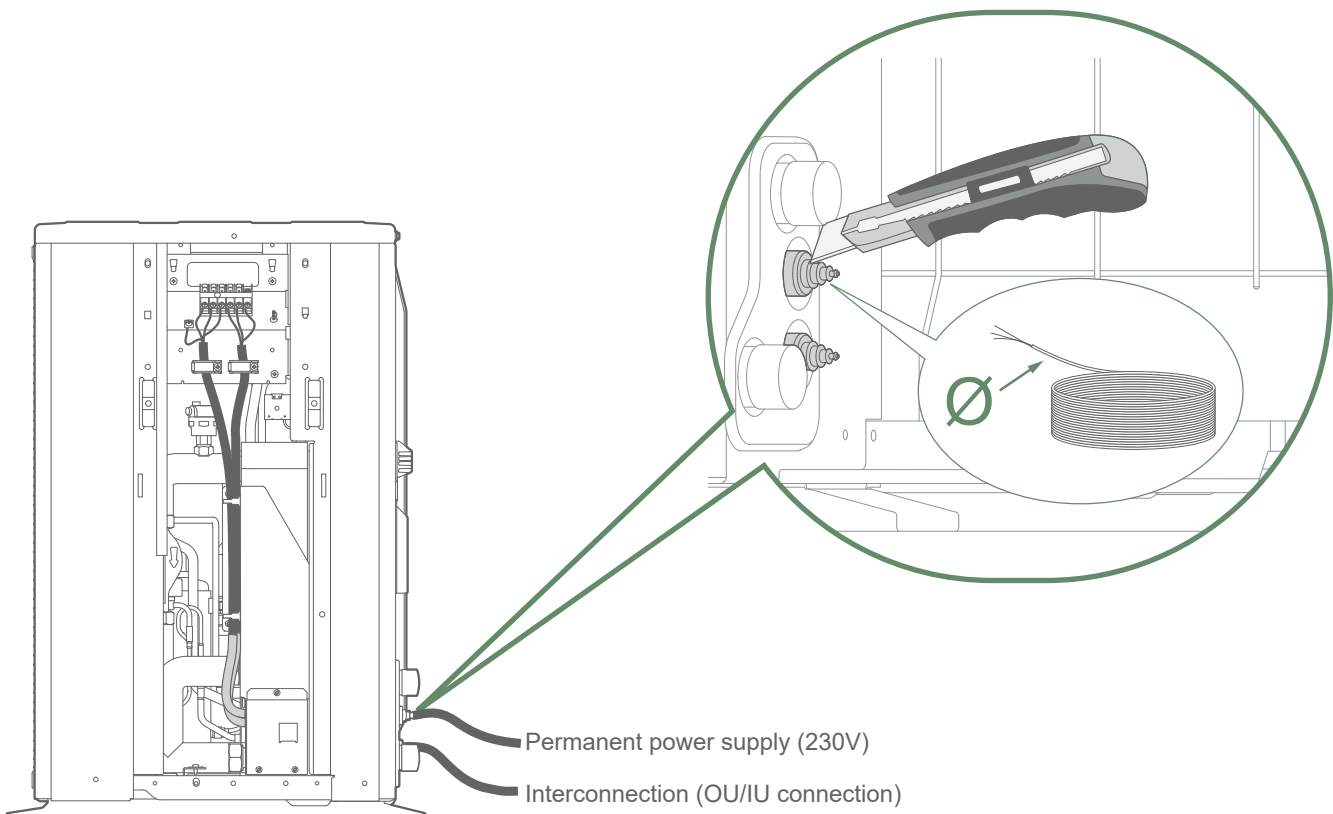
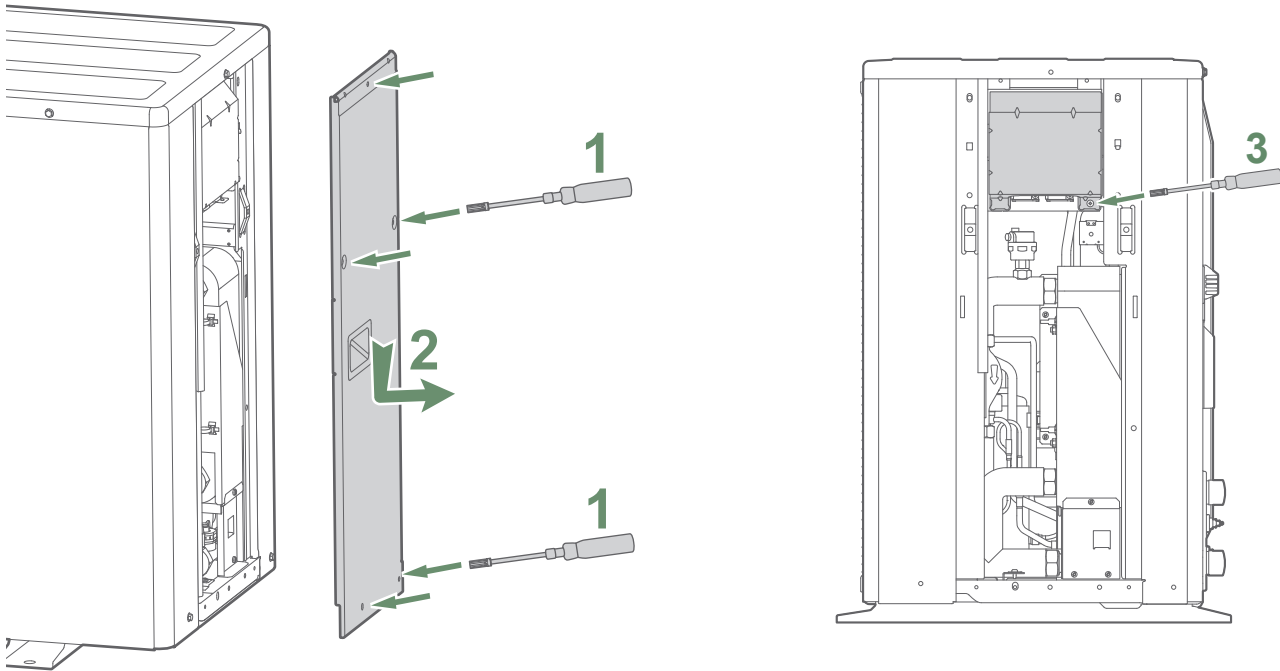

## ► Cable size and protection rating

These cable dimensions are provided for information purposes only and do not exempt the installer from checking that these dimensions match requirements and comply with current standards.

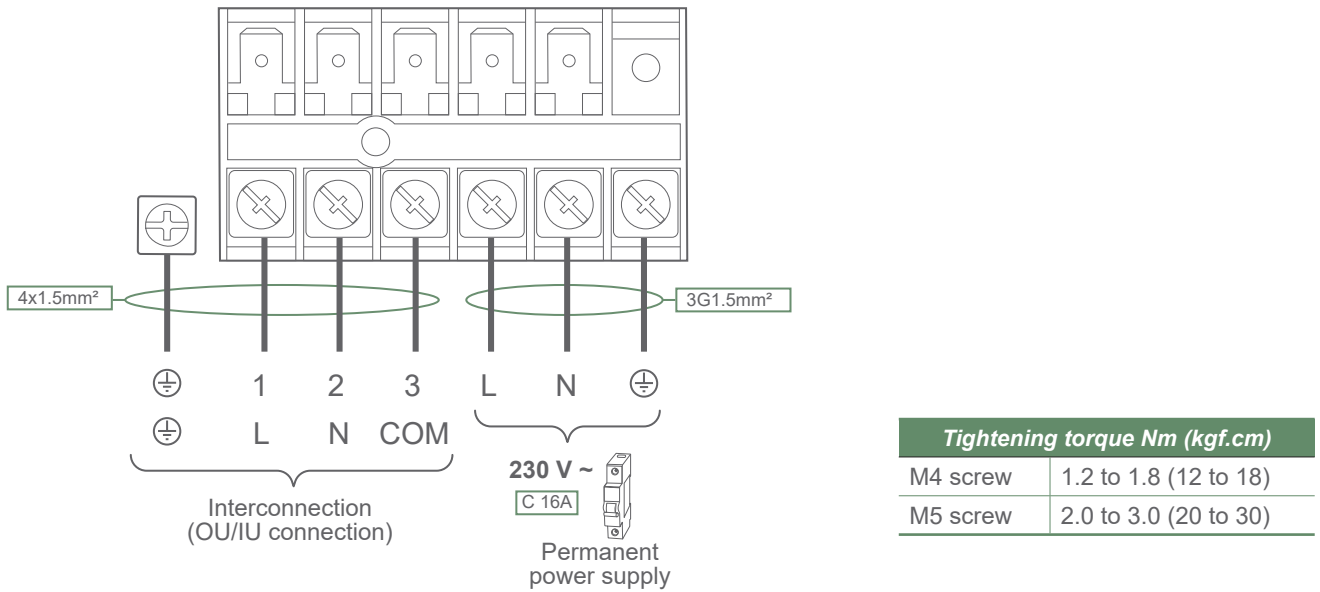

fig. 11 - Connections to outdoor unit's terminal block

# Appendices

## ► Electrical cabling diagram

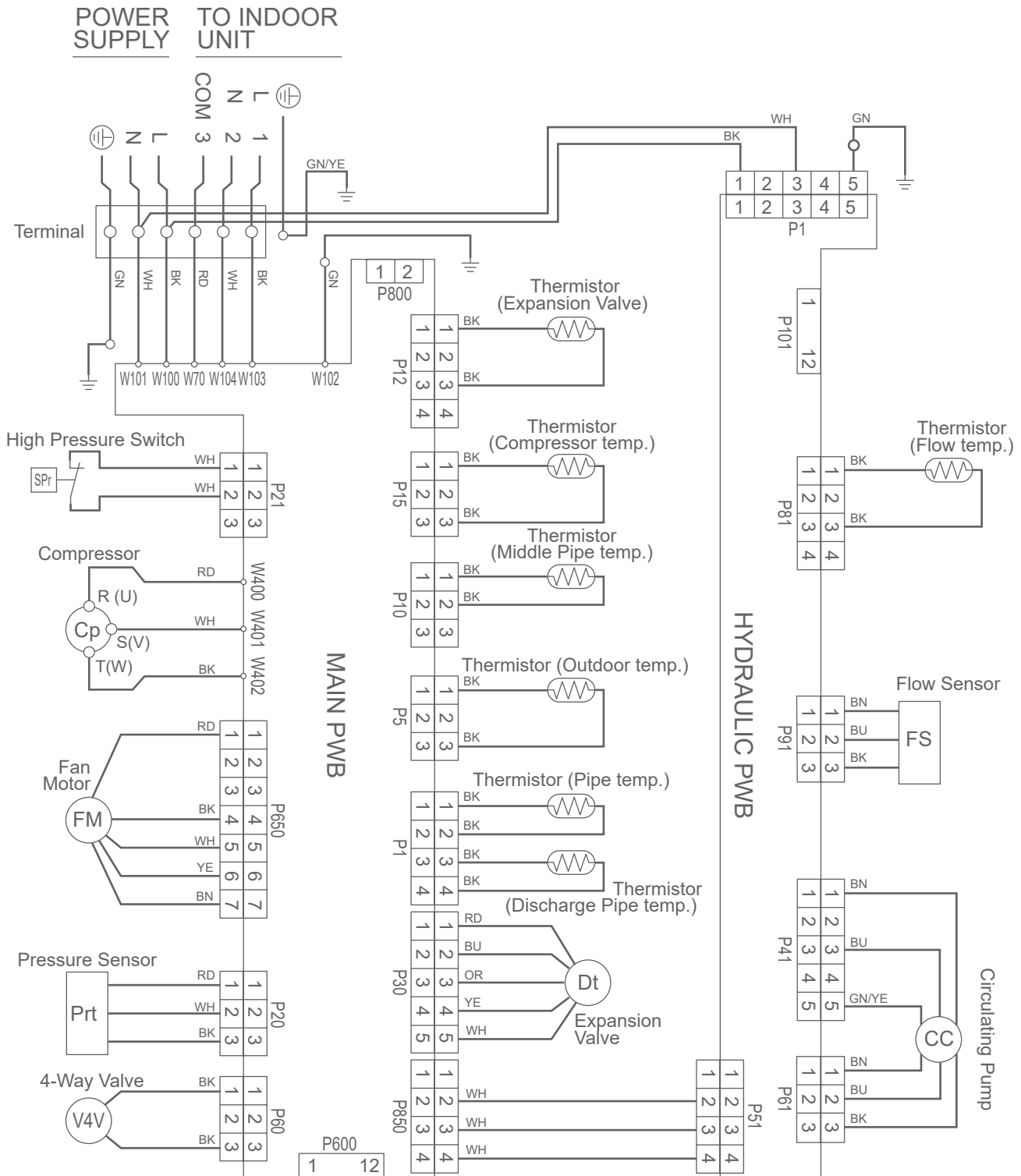

fig. 12 - Outdoor unit electrical cabling

# Commissioning

---



The outdoor unit must have the power active for a minimum of 6 hours prior to activation of the heat pump to protect the compressor.

See the Installation manual of the indoor unit.

## Instructions for the user

---



Explain to the user how the installation operates, in particular the functions of the room thermostat and the programmes accessible via the user interface.

Emphasise that a heated floor has significant inertia and that therefore any adjustments must be made progressively.

Also explain to the user how to check the filling of the heating circuit.

# Heat pump error code

## ■ Flashing of the diode visible on the interface board in the indoor unit

x N : LED blink N time

Error	Interface Board		Error designation
	Green LED	Red LED	
11	x 1	x 1	Serial forward transmission error immediately after operation
	x 1	x 1	Serial forward transmission error during operation
23	x 2	x 3	Combination error
32	x 3	x 2	Outdoor unit PCB model information error
62	x 6	x 2	Communication error in outdoor unit
65	x 6	x 5	IPM error
71	x 7	x 1	Discharge temp. sensor error
72	x 7	x 2	Compressor temp. sensor error
73	x 7	x 3	Heat Ex. middle temp. sensor error
	x 7	x 3	Outdoor unit Heat Ex. liquid temp. sensor error
74	x 7	x 4	Outdoor temp. sensor error
78	x 7	x 8	Electric expansion valve sensor error
79	x 7	x 9	Water outlet temp. sensor error
84	x 8	x 4	Current sensor error
86	x 8	x 6	High pressure switch error
	x 8	x 6	Pressure sensor error
94	x 9	x 4	Trip detection
95	x 9	x 5	Compressor motor control error
97	x 9	x 7	Outdoor unit fan motor 1 error
9B	x 9	x 11	Circulation pump error
A1	x 10	x 1	Discharge temp. error
A3	x 10	x 3	Compressor temp. error
A5	x 10	x 5	Low pressure error
AE	x 10	x 14	Low water flow error



A series of horizontal dotted lines spanning the width of the page, providing a guide for handwriting practice.

Date of installation : :

Contact of your heating technician or your after-sales service.



are in conformity with the relevant Union harmonized directives and regulations:

- Low Voltage Directive (LVD) - 2014/35/EU
- Machinery Directive - 2006/42/EC
- ElectroMagnetic Compliance (EMC) Directive - 2014/30/EU
- Commission Regulation / Directives - (EU) 811/2013
- Energy labelling ; Ecodesign - (EU) 2017/1369 - 2009/125/EC
- RoHS Directive - 2011/65/EU - (EU) 2015/863
- Pressure Equipment Directive (PED) - 2014/68/EU

Pressure equipment: Compressor (including its accumulator), Pressure switch, Sub-assembly SKD.

Risk Category II, conformity assessment procedure : module A2 (internal production control plus supervised pressure equipment checks at random intervals) by the Notified Body: TÜV Rheinland Industrie Service GmbH, D-51105 Köln (Identification N° : 0035)



This unit is identified by this symbol. It means that all electrical and electronic products must not be included in household waste.

A specific recycling system for this type of product has been set up in European Union countries (\*), Norway, Iceland and Liechtenstein.

Do not try to dismantle this product yourself. It may have damaging effects on your health or on the environment.

Reprocessing of the refrigerant, lubricant and other parts may be performed by a qualified installer in compliance with the local and national legislation in force.

This unit must be recycled by a specialised service and in no case may it be thrown away with household waste, rubble or in a landfill.

Please contact your installer or local representative for more .

\* Depending on the national regulations of each member state.